

ANALYSIS AND OPTIMIZATION OF A MOVING-MAGNET LINEAR ACTUATOR WITH RING MAGNETS

BY

C. ASTRATINI-ENACHE^{*}, R. OLARU, R. HERȚANU and R. GHERCĂ

“Gheorghe Asachi” Technical University of Iași,
Faculty of Electrical Engineering, Energetics
and Applied Informatics

Received, June 14, 2011

Accepted for publication: August 16, 2011

Abstract. The paper presents a numerical field analysis with COMSOL Multiphysics software for the optimization of a linear moving-magnet actuator (LMMA). In order to improve the performance of the actuator that uses ring permanent magnets with given sizes, a series of simulations are made to obtain a higher thrust force and a larger displacement. Simulations were performed taking into account the influence of coils geometry and outer ferromagnetic cover.

Key words: electromagnetic actuator; permanent magnets; thrust force.

1. Introduction

As a consequence of recent achievements in advanced magnetic materials and developments in the areas of power electronics, microprocessor and digital control strategies, and due to the continuous application of high performance motion control systems, currently there is a high research activity and development of electromagnetic actuators with permanent magnets for applications that include all economic sectors.

Moving magnet type actuators with linear motion have the mobile element (translator) constituted by a shaft and one or more cylindrical shape

^{*} Corresponding author: *e-mail*: aecipy@yahoo.com

permanent magnets (Hirabayashi *et al.*, 1995; Lu *et al.*, 2008).

Magnetic field and force acting upon the mobile magnet are numerically determined in this paper using the software COMSOL Multiphysics software, based on the finite element method (Al-Sharif *et al.*, 2010; COMSOL Multiphysics, 2010).

Considering other actuators models in the technical literature (Hirabayashi *et al.*, 1995; Lu *et al.*, 2008; Petrescu & Olaru, 2009) or previous performed studies (Astratini-Enache *et al.*, 2010), a technical solution is analysed (Astratini-Enache & Herțanu, 2009), in order to improve the performance by increasing the thrust force without increasing the overall size.

2. LMMA with Elasto-Magnetic Forces

The studied linear moving-magnet actuator (LMMA) is shown in Fig. 1 and is composed of two identical opposing windings; two moving magnets made of rare-earth material connected to a non-magnetic rod (or translator) that transmits motion to the outside, and two smaller ring magnets, positioned at both ends. If mobile magnets poles are opposite to fixed magnets poles the repulsive forces are generated (elasto-magnetic forces typically). The opposing configuration allows LMMA open loop control of position and stiffness.

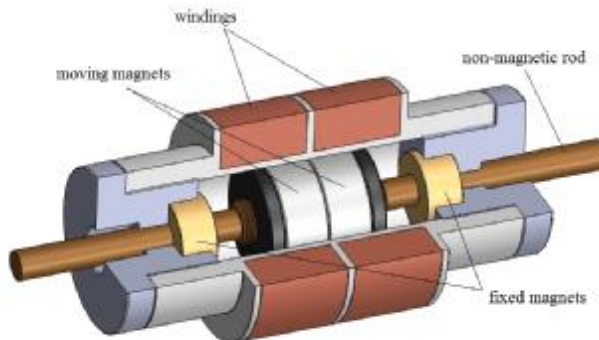

Fig. 1 – LMMA with elasto-magnetic forces.

For an experimental model used as a reference in the optimization process, displacement *vs.* current characteristics was drawn using experimental and simulation data (Fig. 2). Determinations are performed for a command current ranging between 0...0.2 A, and obtained a maximum displacement of 2.5 mm for the mobile element.

Optimal distance between mobile and fixed magnets was analysed, because using rare-earth magnets (neodymium magnets), repulsive forces generated between magnets are relatively high.

Taking into account that for operation in a vertical position of LMMA, additional forces appear of approximately 0.26 N, to maintain the mobile

element in central position, a distance of 11 mm between fixed and mobile magnets was chosen.

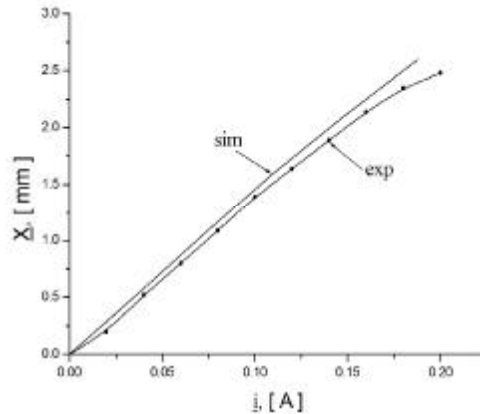

Fig. 2 – Displacement vs. current characteristics (simulated and experimentally).

3. Influence of Coil Geometry

Shape, number of turns or maximum current that is supported by coils is reflected in the obtained force vs. displacement characteristic. A series of simulations were made to determine optimal form of coils, comparing the thrust force of moving element in central position (Fig. 3). Same 0.1 A current is applied in all studied cases, modifying the length or thickness of the coil by adding or removing turns.

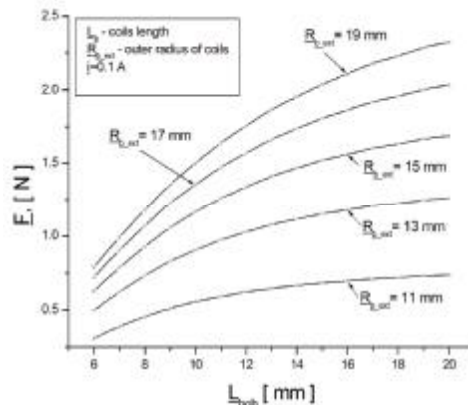

Fig. 3 –Thrust force in central position for different coil dimensions.

Considering the position of other parts which form LMMA and maintaining overall size, exterior radius of the coils is retained, modifying the

length by adding turns, thus keeping constant actuator sizes and obtaining higher forces/displacements to the output. Was chosen a coil length of 19.5 mm which covers half of fixed magnets, and, in consequence, a force of about 1.76 N was obtained.

4. Influence of Outer Ferromagnetic Parts

Adding ferromagnetic parts has several advantages such as: increasing force/displacement obtained, economies of magnetic material that reflects in production costs or magnetically shielding to the outside of LMMA (when ferromagnetic cover is added). In this case the influence of a cylindrical ferromagnetic cover (c_2) or of a cylindrical and circular cap ferromagnetic cover (c_3) is studied (Fig. 4).

A series of tests were carried out regarding the thickness of ferromagnetic cover, the distance from the coils, and its length, and was concluded that covering the entire LMMA with ferromagnetic parts attached to the outer surface of coils and adding ferromagnetic circular cap cover at 4 mm distance from fixed magnets with a thickness of 1 mm represents an optimal solution.

In case of using cylindrical ferromagnetic cover, a movement of about 4.27 mm is obtained for a current of 0.18 A. But if we want to create a totally exterior magnetically shielding of the LMMA, adding ferromagnetic circular cap cover to the exterior is also required, but a lower displacement is obtained.

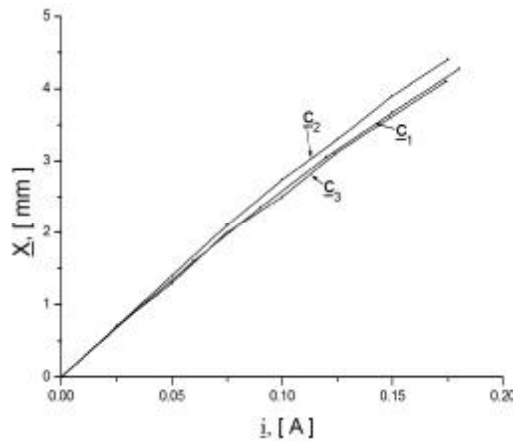

Fig. 4 – Displacement vs. current for different ferromagnetic configurations of the LMMA: c_1 – without ferromagnetic cover; c_2 – with cylindrical ferromagnetic cover; c_3 – with cylindrical and circular cap ferromagnetic cover.

A comparison between the displacement initially obtained ($LMMA_{init}$), and displacement obtained after optimization ($LMMA_{optim}$) is plotted in Fig. 5. It can be observed that after optimization a higher movement of mobile element is obtained, caused by a greater force developed.

It has been also made some simulations for magnetic flux density in the outside of LMMA (Fig. 6), considering in all cases a measurement line above cylindrical ferromagnetic cover at 0.5 mm of outer surface for three cases: a) when ferromagnetic parts are not used (M_{f1}), b) when cylindrical outer ferromagnetic cover is used (M_{f2}), or c) when cylindrical and circular cap ferromagnetic cover are added (M_{f3}).

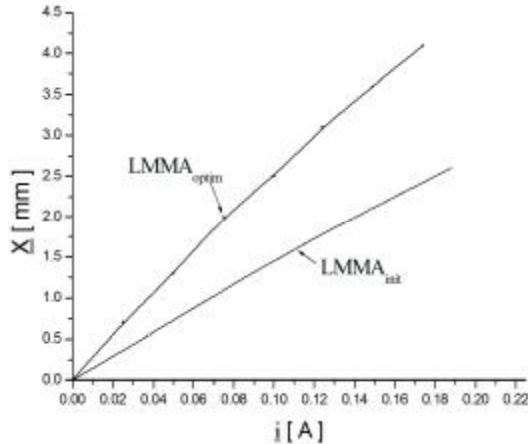

Fig.5 – Displacement vs. current characteristic (simulation).

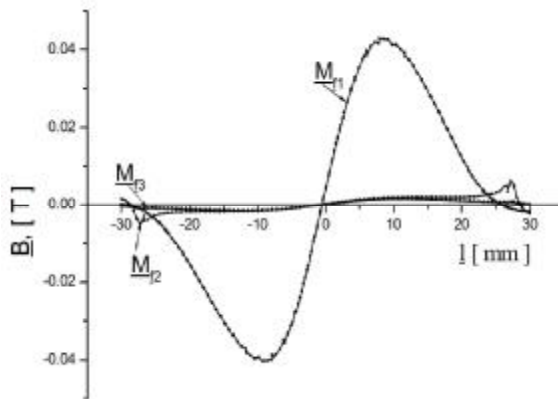

Fig.6 – Simulation of magnetic flux density outside of LMMA.

5. Conclusions

Development of innovative multifunctional actuators, with dimensions as small as possible, depends on size of available magnets. Using the presented configurations, a higher force/displacement was obtained with the same permanent magnet material, thus reducing the cost of production.

Cylindrical ferromagnetic cover can lead to the improvement of thrust

force, while a ferromagnetic full cover, although not significantly affecting the force, ensures a very good magnetic shielding.

In some cases, depending on working environment, magnetic shielding of LMMA is essential, so considering the improved performance and the advantages it offers LMMA (low response time, many working hours, and a simple construction) can be an alternative of hydraulic or pneumatic systems currently used, without taking into account current applications of LMMA.

Finite-element analysis using Comsol Multiphysics software is an efficient method to obtain information on the performance of the LMMA. Different configurations can be easily analysed in terms of influence parameters that occur, leading to the system optimization.

REFERENCES

- Al-Sharif L., Taifour S., Kilani M., *Simulation and Verification of the Axial Force of Linear Permanent Magnet Synchronous Actuator*. Internat. J. of Appl. Electromag. and Mech., **32**, 249-265 (2010).
- Astratini-Enache C., Olaru R., Petrescu C., *Moving Magnet Type Actuator with Ring Magnets*. J. of Electr. Engng. (Elektrotechnicky Casopis), **61**, 7/s, 144-147 (2010).
- Astratini-Enache C., Herțanu R., *Actuator miniaturizat de cursă scurtă cu magneți permanenți*. Patent Appl. OSIM, nr. A/00502, (2009).
- Hirabayashi Y., Oyama T., Sohno H., Saito S., *Moving Magnet-Type Actuator*. US Patent No. 5434549 (1995).
- Lu H., Zhu J., Lin Z., Guo Y., *A Miniature Short Stroke Linear Actuator – Design and Analysis*. IEEE Trans. on Magnetics, **44**, 4, 497-504 (2008).
- Petrescu C., Olaru R., *Study of a Mini-Actuator with Permanent Magnets*. Adv. in Electr. a. Comp. Engng., **9**, 3-6 (2009).
- * * COMSOL Multiphysics, AC/DC Module – User's guide (2010).

ANALIZA ȘI OPTIMIZAREA UNUI ACTUATOR LINIAR DE TIP MAGNET MOBIL PREVĂZUT CU MAGNEȚI INELARI

(Rezumat)

Se prezintă rezultatele unei analize numerice de câmp magnetic utilizând softul COMSOL Multiphysics pentru optimizarea unui actuator liniar cu magneți mobili. Pentru îmbunătățirea performanțelor actuatorului ce utilizează magneți permanenți inelari cu dimensiuni date, sunt realizate simulări în vederea obținerii de forțe axiale crescute. Simulările sunt realizate ținând cont de influența geometriei bobinelor și a carcasi feromagnetice exterioare.